



# Atlas Workholding Super Thin Round Chucks

## Series NBK

### The Ultimate Low Profile 3-Jaw Universal Chuck

- ⊕ Three operating pinions positioned at a 45 degree angle for easier operation.
- ⊕ Sizes available 6, 8, 10 and 12 inch diameter.
- ⊕ Easy Installation with flange type mounting.
- ⊕ One Year Warranty
- ⊕ Accurate- .001" repeatability on duplicate parts using the nominated pinion.
- ⊕ Ideal for Drill Presses, Standard Mills, Vertical Machining Centers, Angle Plates, Tombstones, and Grinding Machines.
- ⊕ American standard hard top and master jaws

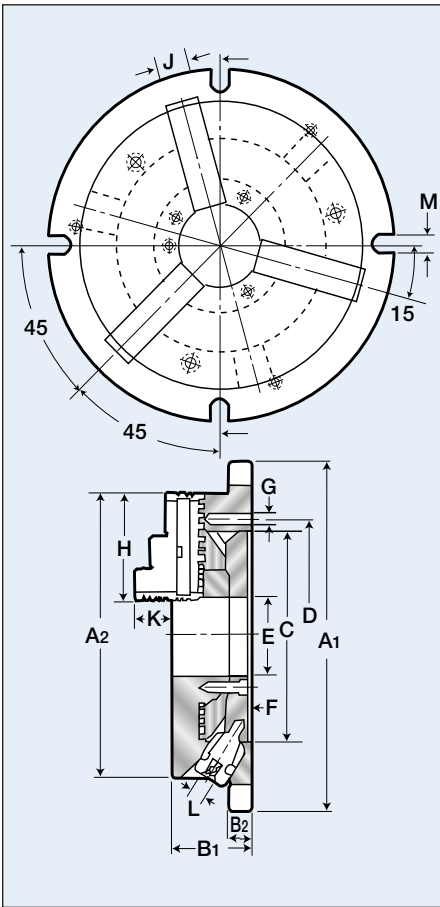

Model	Approx. Weight	Gripping capacity			
		External		Internal	
		Min.	Max.	Min.	Max.
NBK6	24 lbs.	.31"	6.30"	1.89"	5.91"
NBK8	40 lbs.	.43"	7.87"	2.44"	7.48"
NBK10	62 lbs.	.47"	9.84"	2.83"	9.41"
NBK12	95 lbs.	.59"	11.81"	3.38"	11.41"

### Dimensional Data (in inch)

Model	A1	A2	B1	B2	C	D	E	F	G	H	J	K	L	M
NBK6	8.66	6.69	2.28	.71	5.12	5.79	1.77	.24	3-M10x1.5P	2.68	1.02	1.57	.394*	.512
NBK8	10.63	8.27	2.56	.78	6.10	6.77	2.36	.24	3-M10x1.5P	3.23	1.10	1.69	.433*	.512
NBK10	12.40	10.04	2.87	.78	7.48	8.27	3.15	.24	3-M12x1.75P	3.66	1.26	2.04	.472*	.630
NBK12	14.57	12.00	3.15	.87	9.84	11.22	4.13	.21	3-M12x1.75P	4.64	1.57	2.32	.551*	.708

\*square drive

HOW TO ORDER: State quantity, Model Number of chuck and shipping instructions.